



KUADRA CUCINE presenta questa nuova collezione per ampliare l'offerta del prodotto ed estenderlo in maniera decisa a tutta la zona giorno.

Le composizioni presentate in questo catalogo possono essere applicate a tutti i modelli e rappresentano solo una piccola parte di quanto realizzabile, si tratta di proposte personalizzabili con grande flessibilità sia nelle dimensioni che nelle finiture, sia per i **living** che per le **madie**.

KUADRA CUCINE presents this new collection to expand the product offer and extend it decisively to the entire living area.

The compositions presented in this catalogue can be applied to all models and represent only a small part of what can be realised, these are proposals that can be customised with great flexibility in terms of both dimensions and finishes, for both living rooms and sideboards.

living



da pag. 4

LIVING .01



colori e finiture in foto:
colours and finishes in the picture:
 CALCE BETON (mod. PRIME)
 ANTRACITE (mod. PRIME)
 ANTA VETRO telaio nero, vetro fumè



calce beton

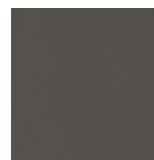

antracite

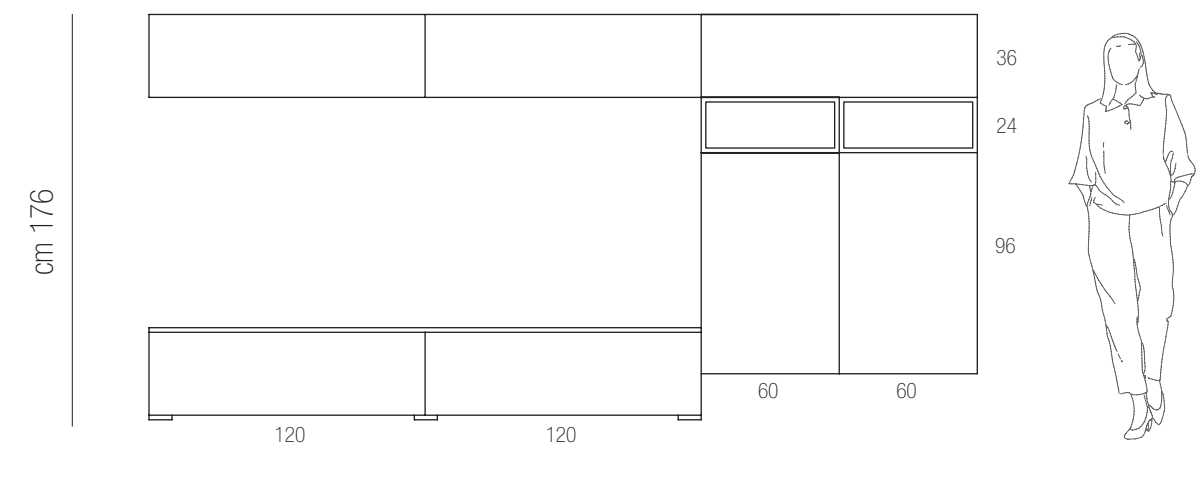

schema della composizione
composition scheme

cm 360

LIVING .02



colori e finiture in foto:
colours and finishes in the picture:
 NOCE CANALETTO (mod. PRIME)
 GRIGIO CHIARO TOP MATT (mod. PRIME)



noce canaletto



grigio chiaro top matt

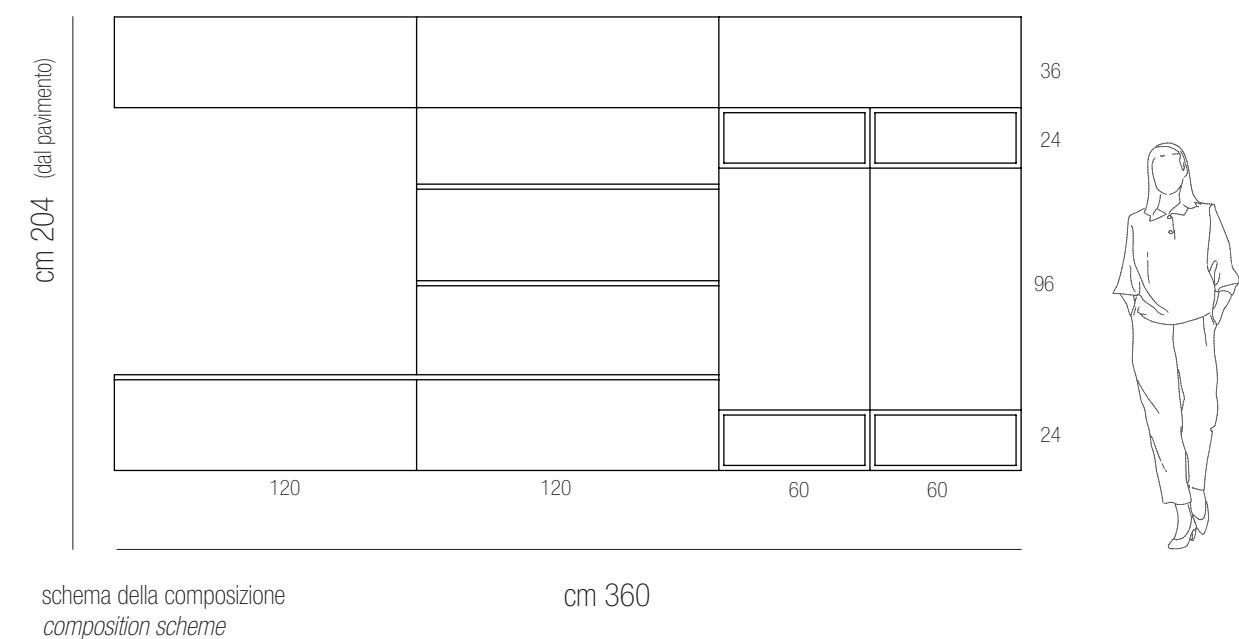



colori e finiture in foto:
colours and finishes in the picture:
ATELIER NOTTE (mod. MAYA)
POLVERE CURRY (mod. MAYA)

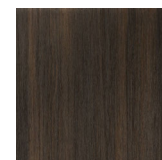

atelier notte



polvere curry

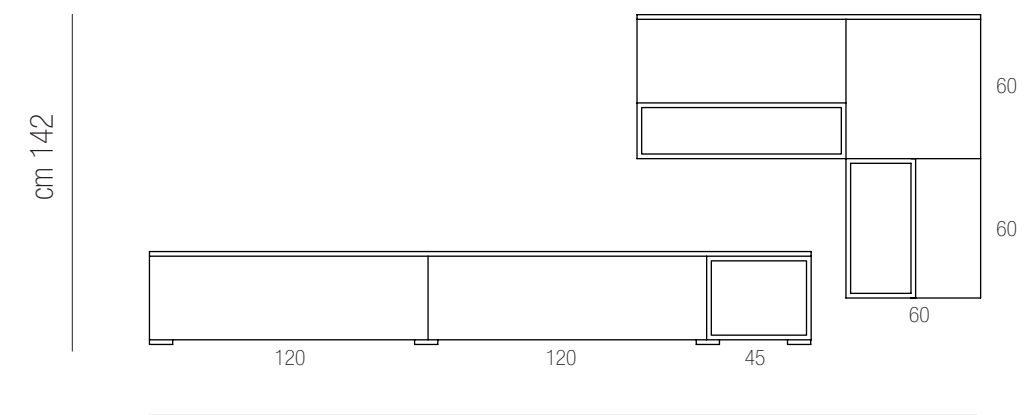

schema della composizione
composition scheme

cm 360



colori e finiture in foto:
colours and finishes in the picture:
 NOCE MEDIO (mod. PRIME)
 POLVERE TORTORA (mod. PRIME)



noce medio



polvere tortora

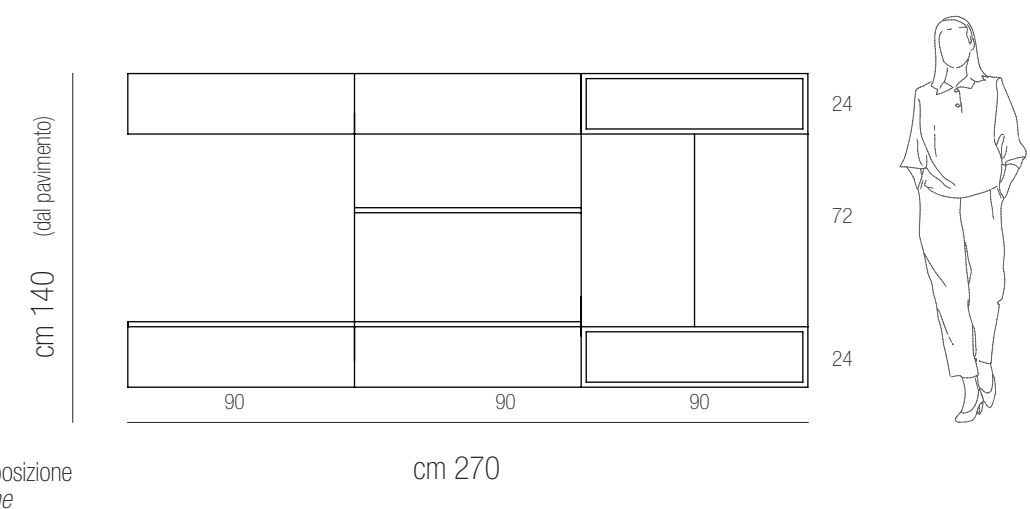



colori e finiture in foto:
colours and finishes in the picture:
 DOGATO BORNEO sp. 18 (mod. YARIS)
 POVERE ANTRACITE sp. 18 (mod. PRIME)



dogato borneo



polvere antracite

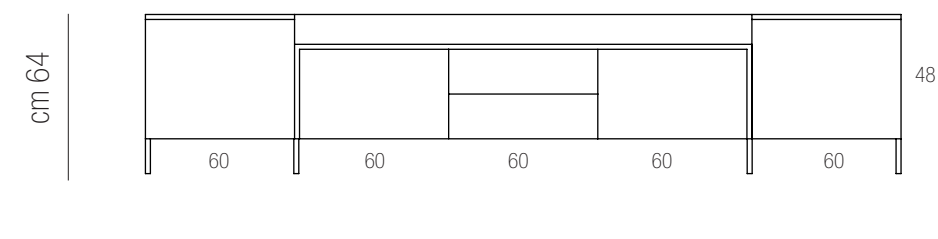

schema della composizione
composition scheme

cm 304





colori e finiture in foto:
colours and finishes in the picture:
TORTORA METAL (mod. TIME)
NOCE GRIGIO (mod. PRIME)



tortora metal



noce grigio

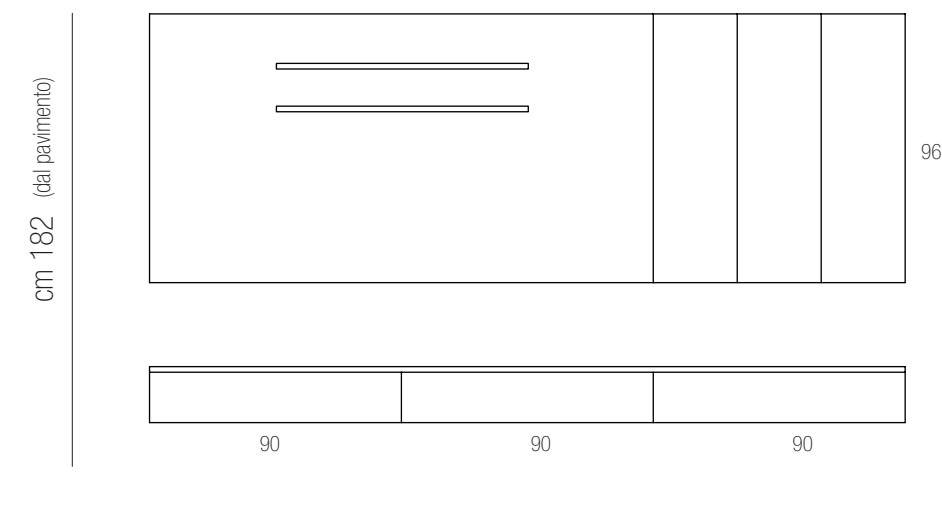

schema della composizione
composition scheme

cm 270



colori e finiture in foto:
colours and finishes in the picture:
 ARDESIA (mod. LINEA)
 CORDA (mod. LINEA)
 NOCE GRIGIO (mod. PRIME)



ardesia



corda



noce grigio



schema della composizione
composition scheme





Madia cm L 244 H 72

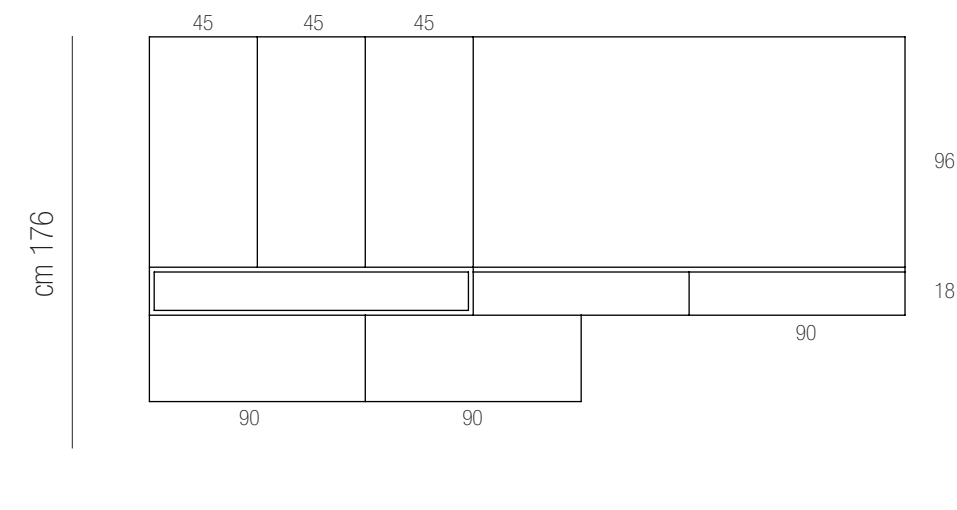

schema della composizione
composition scheme

cm 315

colori e finiture in foto:
colours and finishes in the picture:
VERDE MALGA (mod. FLAT)
NOCE CANALETTO (mod. PRIME)



verde malga

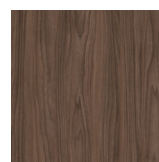

noce canaletto



Madia cm L 244 H 72

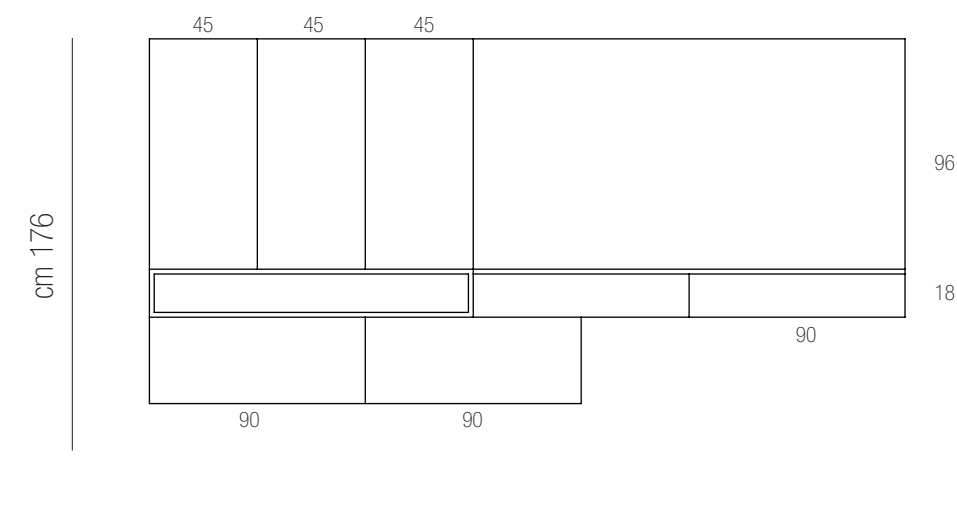

schema della composizione
composition scheme

cm 315

colori e finiture in foto:
colours and finishes in the picture:
ROSA CIORIA (mod. LINEA)
PELTRO TOP MATT (mod. PRIME)

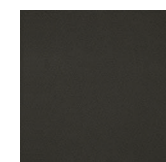

peltro top matt



rosa cipria

LIVING .10



colours and finishes in foto:
colours and finishes in the picture:
 LAVA (mod. LINEA)
 CORDA (mod. LINEA)
 PAPPICA POLVERE (MAYA)



lava



corda



paprka polvere

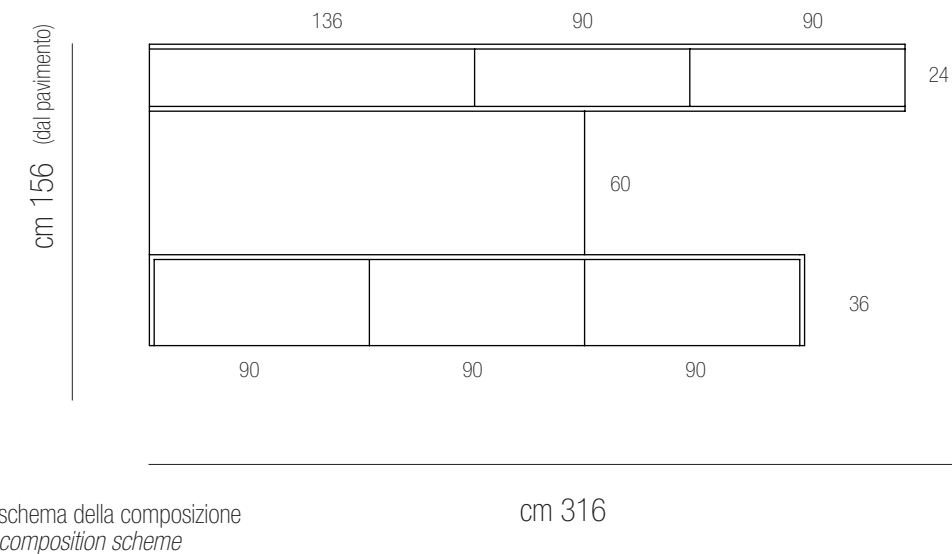



colori e finiture in foto:
colours and finishes in the picture:
 FRASSINO NERO (mod. MAYA)
 ANTRACITE (mod. PRIME)



frassino nero



antracite

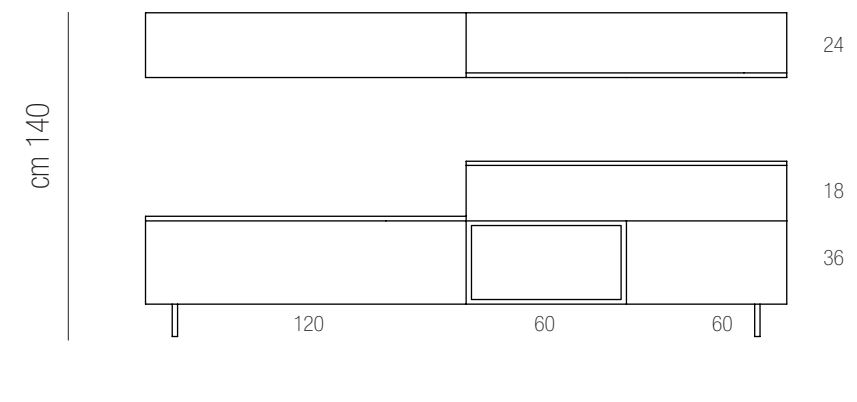

schema della composizione
composition scheme

cm 240



LIVING .12



colori e finiture in foto:
colours and finishes in the picture:
ATELIER NOTTE (mod. MAYA)
POLVERE SALVIA (mod. MAYA)

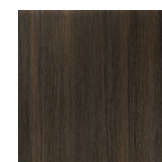

atelier notte



polvere salvia

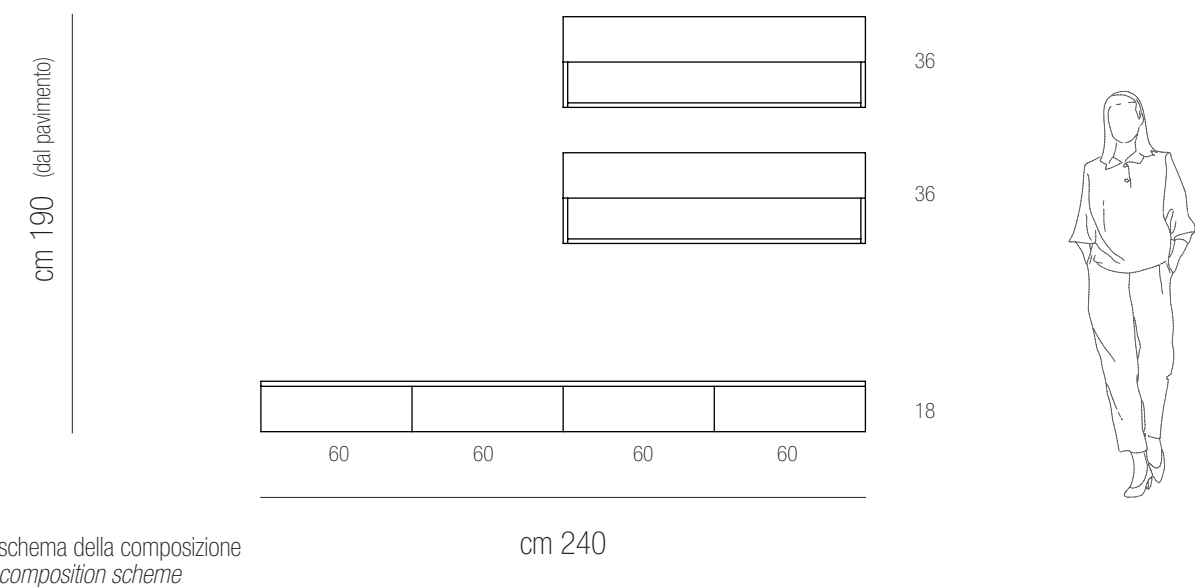

LIVING .13



colori e finiture in foto:
colours and finishes in the picture:
 PIOMBO (mod. YARIS)
 GRIGIO PIETRA (mod. YARIS)
 BIANCO (mod. YARIS)



piombo



grigio pietra



bianco

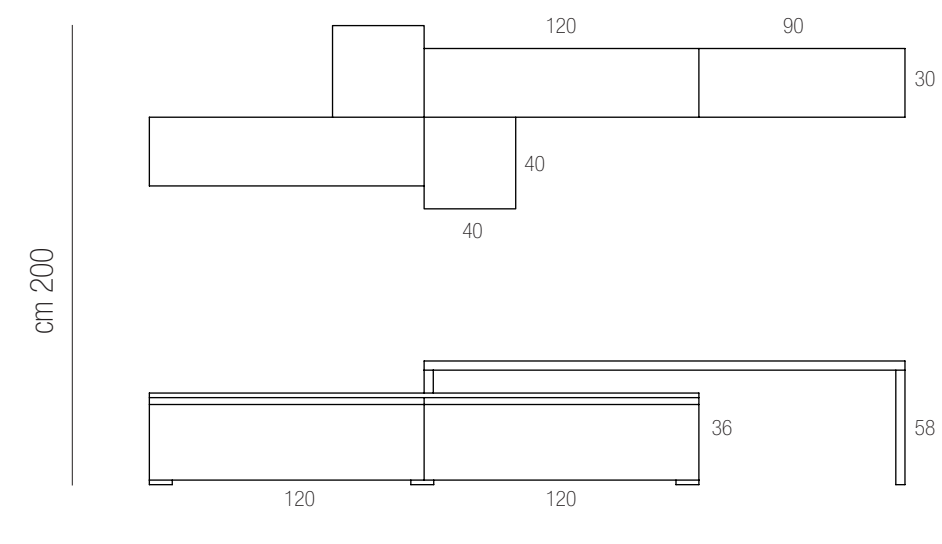

schema della composizione
composition scheme

cm 330



colori e finiture in foto:
colours and finishes in the picture:
 MARMO NERO (mod.MAYA)
 POLVERE TORTORA (mod. MAYA)
 ANTRACITE

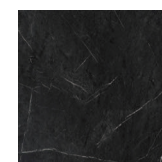

marmo nero



polvere tortora



antracite

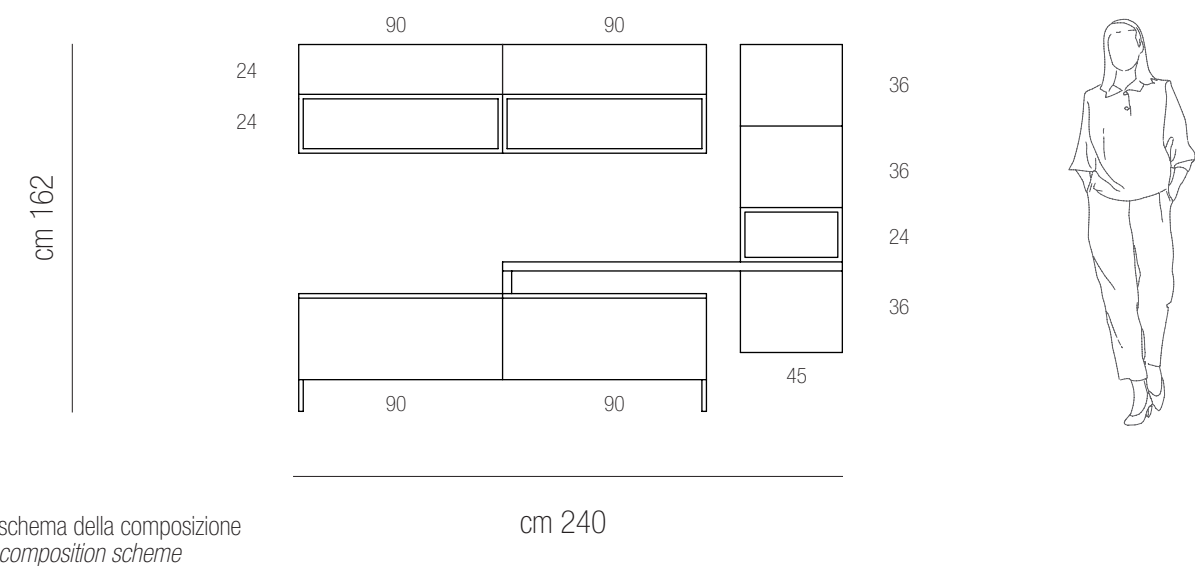

LIVING .15



colori e finiture in foto:
colours and finishes in the picture:
GRIGIO PIOMBO (mod. YARIS)
GRIGIO PIETRA (mod. YARIS)



grigio piombo



grigio pietra

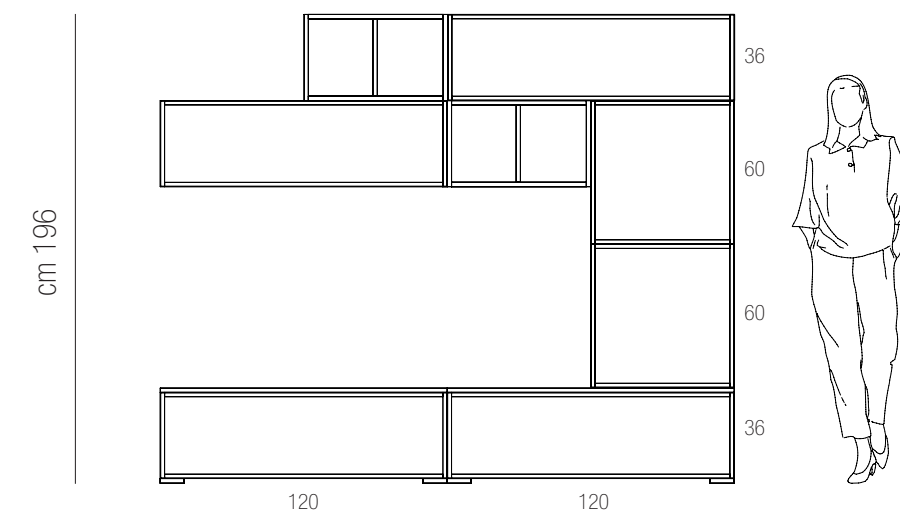

schema della composizione
composition scheme

cm 240

LIVING .16



colori e finiture in foto:
colours and finishes in the picture:
TORTORA TOP MATT (mod.PRIME)
NOCE CANALETTO (mod. PRIME)



tortora top matt

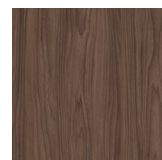

noce canaletto

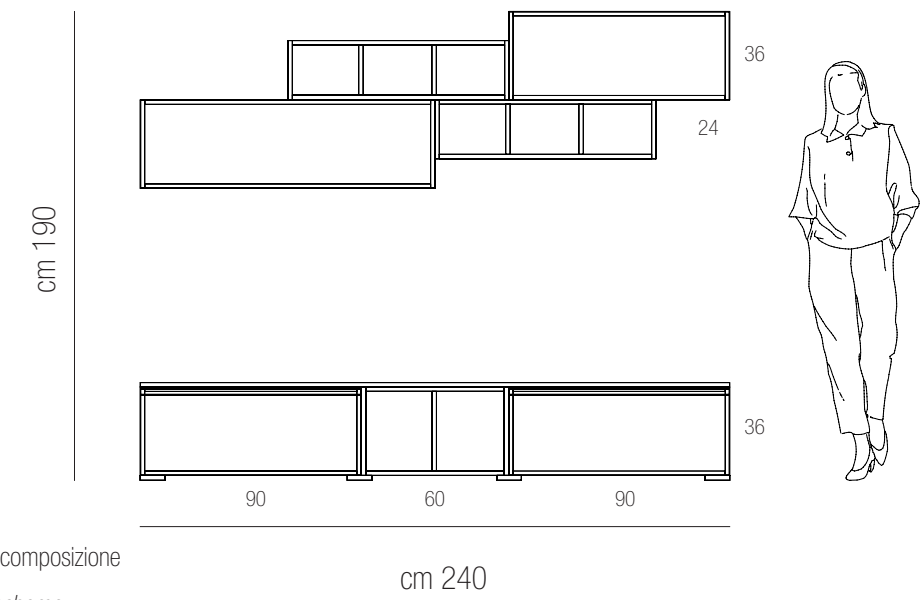

LIVING .17



colori e finiture in foto:
colours and finishes in the picture:
NOCE NATURALE (mod. PRIME)
ANTRACITE (mod. MAYA)



noce naturale



antracite

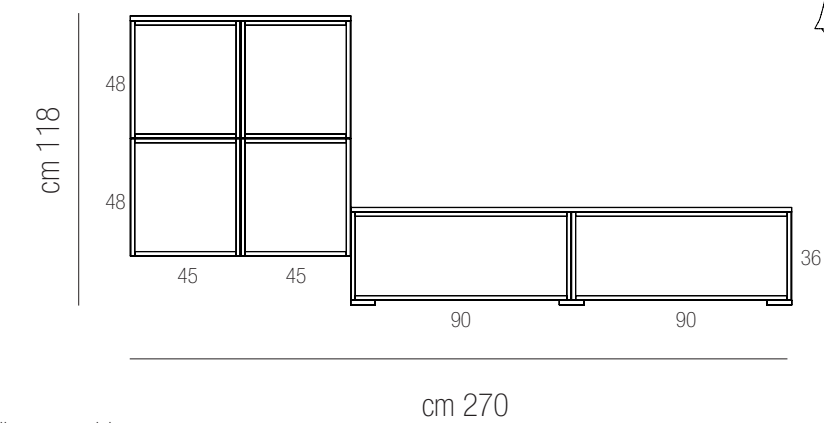

schema della composizione
composition scheme

